



# AC SERVO SYSTEMS

**SANYO DENKI** **SANMOTION**  
AC SERVO SYSTEMS

Catalogue



*Motion Control Systems*

# Index

▶	PRESENTATION	page	1
▶	BRUSHLESS 230 V <sub>AC</sub> SERVOAMPLIFIERS R and R CANopen SERIES	page	2
	• Technical data	page	3
	• R - Setup software	page	3
▶	BRUSHLESS SERVOMOTORS R2, P5, Q2 and Q1 SERIES	page	4
	• Technical data	page	5
	• Overload curves	page	5
	• Torque curves	page	6 - 7
	• Mechanical drawings R2 series	page	8
	• Mechanical drawings P5 series	page	9
	• Mechanical drawings Q2 series	page	10 - 11
	• Mechanical drawings Q1 series	page	12 - 13
▶	AMPLIFIERS' OUTLINE DRAWINGS	page	14 - 15
▶	ACCESSORIES		
	• Serial connection kit: STARTER KIT RSK	page	16
	• Amplifier-motor connection cables	page	16
	• External regenerative resistor	page	16



## Warning

- The sole purpose of this catalogue is as a general introduction to our products, in order to allow an orientation as well as a choice among them. Detailed information concerning limitations and installation/utilization procedures are described in the manuals relating to each product. It is therefore essential to strictly refer to these enclosed technical manuals for a correct use, in accordance with current standards.
- All those products for which a specific obligation is required, as per law regulation in force in the European Community countries, bear the EC marking stating they are in accordance with the related directives (depending on the products, 2006/95/CE and/or 2004/108/CE and subsequent modifications and integration).
- All products are classed as components foreseen to be integrated in a more complex machine or installation by a professional assembler, expert in the field of motor drives and in their related problems. Only a professional assembler can install and put in service this component. The necessary installation recommendations are included in the technical manuals.
- R.T.A. reserves the right to modify the products at any time and without prior notice (including, but not limited to, characteristics, availability and prices).

# SANYO DENKI AC SERVO SYSTEMS catalogue

**SANYODENKI**, a world leader in the motion control industry, has recently presented the R Series Brushless Servoamplifiers, coupled with AC servomotors R2, P5, Q2 and Q1, entrusting **R.T.A.** with their distribution.

The available motorization covers a 100 W to 3 KW power range, with maximum torque up to 28 Nm. The motors, equipped with built-in encoder for all versions and featuring maximum speed up to 6000 rpm, are among the most compact in the world and, coupled with proposed servoamplifiers, are characterized by an excellent dynamic behavior.

The product selection offered by **R.T.A.**, chosen from among the models on **SANYODENKI** catalogue and supported by a consistent stock of motors and amplifiers always available at the warehouse, allows to face and solve a wide range of automation problems with maximum efficiency.

**R.T.A.**, with 30-years' experience in solving application problems in the motion control industry, can provide a reliable support to meet customer requirements in the most effective way.

At present, both **SANYODENKI** and **R.T.A.** have implemented Quality Assurance Systems certified according to ISO 9001 (JQA - 0622 and TÜV - 50 100 2153, respectively), following the strategic choice of committing the companies more and more to the quality of the products and services provided.

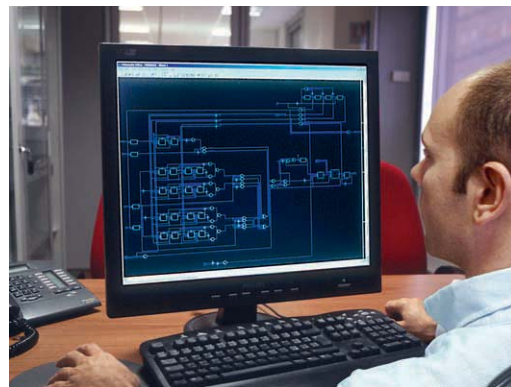

# SANYO DENKI BRUSHLESS 230 V<sub>AC</sub> SERVOAMPLIFIERS R and R CANopen SERIES

## AC SERVOAMPLIFIERS R SERIES

**FIVE DIGIT DISPLAY AND OPERATION KEY:** It allows to view and modify parameters and monitor in real time the behavior of the system.

**PC CONNECTOR:** The amplifier can be set and monitored by means of Personal Computer interface.

**POWER CONNECTOR:** 230VAC, single-phase or three-phase (configurable by user).  
Power sections kept separated for logic/signal and power electronics.  
Built-in protection circuits against any overload and input overvoltage.

**SIGNAL CONNECTOR:** Control: pulse train (clock + direction; forward + backward pulse; 90° phase shift) or analog signal (proportional to speed or torque).  
8 inputs and 8 outputs setting by user.

**CONNECTOR** for external regenerative resistor (optional).

**ENCODER CONNECTOR.**

**MOTOR POWER CONNECTOR**

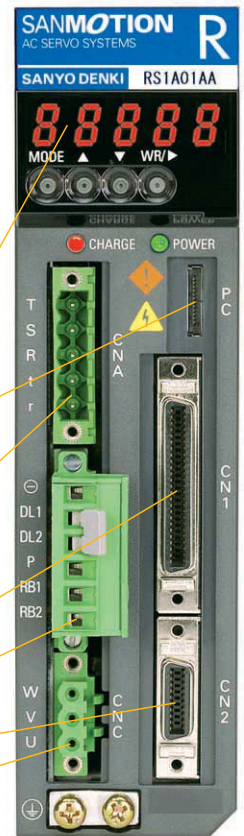

## AC SERVOAMPLIFIERS R SERIES: CANopen version

**SEVEN SEGMENT LED DISPLAY:** allows to monitor amplifier and CANopen.

**CANopen INTERFACE CONNECTOR:** RJ45 with integrated termination resistor.

**SIGNAL CONNECTOR:** 6 inputs and 2 outputs setting by user.

- Bus Connection: CAN-Standard ISO-11898 (High-speed CAN) - Fieldbus: CANopen
- Communication Profile: CiA DS301 Version 4.02 - Device Profile: CiA DSP402 Version 2.0
- Mode of Operation: Homing Mode, Profile Velocity Mode, Profile Position Mode, Interpolated Position Mode, Profile Torque Mode.
- Fast capture "freeze" function.
- EDS file available.

## OTHER CHARACTERISTICS

- Dynamic braking automatic circuit in case of alarm or power off.
- Closed-loop integrated system with Position, Speed and Torque control mode. Possibility of "on fly" changing: position + speed; position + torque; speed + torque (in standard R series).
- **Dynamic self-tuning:** new auto-tuning algorithm with real-time calculation of inertia. New R-Series makes available: 5 auto-tuning modes (from Positioning to Trajectory Control), 30 levels of response for each selected mode. Minimizes start-up period.
- Setting time is reduced by five compared with previous Q Series.
- Vibration and Disturbance Suppression Control.
- Four integrated notch filters to remove any system's resonance frequency.
- Standards: CE, UL and CSA.

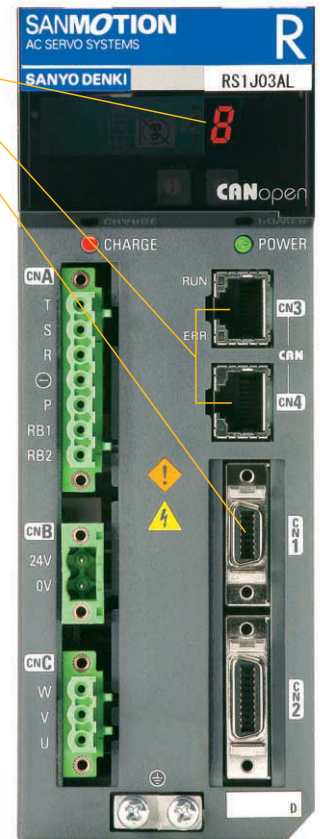

# SANYO DENKI AC SERVO SYSTEMS catalogue

TECHNICAL DATA	Position, Velocity, Torque Control (optional Switching Control Mode)				CANopen Control		
	MODEL	RS1A01	RS1A03	RS1A05	RS1A10	RS1J01	RS1J03
MAX CURRENT	15 Amp	30 Amp	50 Amp	100 Amp	15 Amp	30 Amp	50 Amp
MOTOR OUTPUT STAGE	IGBT, PWM control, sinusoidal current						
POWER SUPPLY VOLTAGE	Single-phase or three-phase (configurable by the user)* 200 VAC or 230 VAC (+10%, -15%) 50/60 Hz ( $\pm 3$ Hz)						
LOGIC SUPPLY VOLTAGE	Single-phase from 200 VAC to 230 VAC (+10%, -15%) 50/60 Hz ( $\pm 3$ Hz)				24VDC (+15%, -15%)		
DIMENSIONS (mm)	45x168x130	50x168x130	90x168x130	100x205x235	60x168x130	60x168x130	90x168x130
MASS (kg)	0.9	1.0	2.2	5.2	1.0	1.11	2.2

\* Model RS1A10 needs 230 VAC three-phase power supply.

## R - SETUP SOFTWARE

The R - Setup communication software enables the parameter setting and the complete control of the system on all its function.

The access to the parameter configuration can be achieved through three levels: basic level, standard level, advanced level.

The software includes a detailed description of all parameters.

Thanks to the R - Setup software it's possible also analyze the system operation through:

- Monitor Display: it shows in real time all information about use of the system.
- Trace Operation: it is a complete oscilloscope with 4 analog and 4 digital channels.
- System Analysis: very helpful to study the system frequency response to view and correct mechanics resonance conditions.

Jogging Operation and Operation Pulse Feed Jogging functions are also available.

## GRAPHIC MONITOR

Thanks to the Integrated oscilloscope function, the real-time variation of some important system parameters (such as speed and torque) can be displayed on the PC screen.

Data can be downloaded and saved in Excel-compatible format.

The time base can be selected in the 10 msec. to 2 sec. range.

Every single value acquired and displayed can be easily read using the cursor.

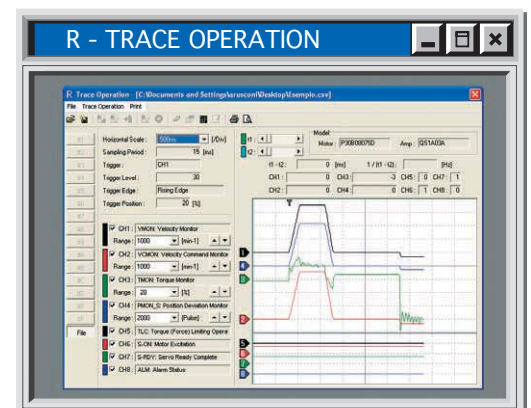
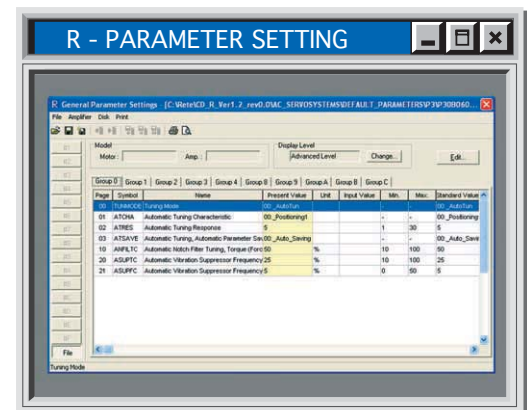
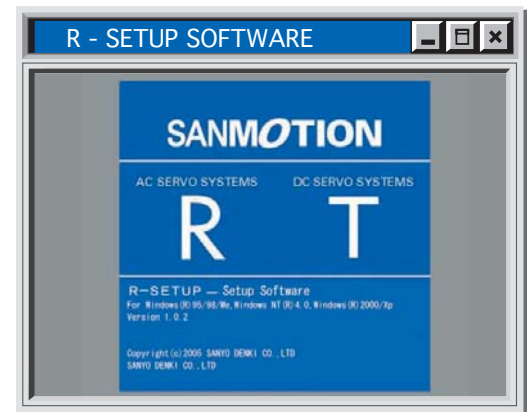

**SANYO DENKI** **SANMOTION**  
AC SERVO SYSTEMS

## AC BRUSHLESS SERVOMOTORS R2, P5, Q2, Q1 SERIES



As part of the range of AC servomotors proposed by Sanyo Denki, we have identified the most interesting models that can be coupled with R drives. All motors can be supplied in the version with brake. The main features of the motors are listed below:

- **R2 Series Motors:** the latest Sanyo Denki servomotor; the world's smallest 10 poles high performance servomotor. The motor can be supplied with absolute encoder.
- **Q1 Series Motors:** very compact, low inertia. Ideal for applications requesting quick acceleration and fast positioning.
- **P5 and Q2 Series Motors:** compact, medium inertia. Ideal for applications in which the load inertia exceeds the motor inertia. Very smooth rotation, even at very low speed.
- IP protection degree: IP55 to IP67 (according to the different models).
- Power range: 100W to 3000W.
- Maximum speed 6000 rpm (4500 rpm on models P5, Q1 and 3000 rpm on model P5 1 kW).
- Perfect behaviour in overload conditions. E.g.: a torque equal to 200% of the nominal torque can be kept for 10 to 20 sec. (according to the different models).
- Proper management of any load characterized by a level of inertia that far exceeds the motor inertia.

A complete map of all of the motor's electrical features is stored in the R drives.

Simply set the model being used with the dedicated software.

All motors are equipped with high quality connectors (Encoder, Motor Phases).

Standards CE/UL.



TECHNICAL DATA		Nominal power (W)	Nominal speed (rpm)	Maximum speed (rpm)	Nominal torque (Nm)	Stall torque (Nm)	Maximum torque (Nm)	Inertia (kg·m <sup>2</sup> )	Encoder (imp./rev)	Weight (kg)	Amplifier
R2 SERIES	R2AA04010FXH1CM	100	3000	6000	0.318	0.318	1.18	0.0627x10 <sup>-4</sup>	131072 (17 bit)	0.39	RS1A01 RS1J01
	R2AA06020FXH11M	200	3000	6000	0.637	0.686	2.20	0.219x10 <sup>-4</sup>	131072 (17bit)	0.84	RS1A01 RS1J01
	R2AA06040FXH11M	400	3000	6000	1.270	1.370	4.80	0.412x10 <sup>-4</sup>	131072 (17 bit)	1.30	RS1A03 RS1J03
	R2AA08075FXH11M	750	3000	6000	2.390	2.550	8.50	1.820x10 <sup>-4</sup>	131072 (17 bit)	2.60	RS1A03 RS1J03

Protection degree R2 SERIES: IP67

P5 SERIES	P50B04010DXS00M	100	3000	4500	0.319	0.353	0.98	0.079x10 <sup>-4</sup>	8000	0.59	RS1A01 RS1J01
	P50B05020DXS00M	200	3000	4500	0.637	0.686	1.96	0.173x10 <sup>-4</sup>	8000	1.07	RS1A01 RS1J01
	P50B07040DXS00M	400	3000	4500	1.274	1.372	3.92	0.740x10 <sup>-4</sup>	8000	2.10	RS1A03 RS1J03
	P50B08100HXS00M	1000	3000	3000	3.185	3.920	8.82	2.651x10 <sup>-4</sup>	8000	5.05	RS1A03 RS1J03

Protection degree P5 SERIES: IP55 (except P50B04010DXS00M)

Q2	Q2AA13150HXS00M	1500	2000	3500	7.5	9.0	20.3	7.94x10 <sup>-4</sup>	8000	7.8	RS1A05 RS1J05
	Q2AA10150BXS48M	1500	2000	2000	7.2	7.7	20.5	7.99x10 <sup>-4</sup>	8000	7.2	RS1A03 RS1J03

Protection degree Q2 SERIES: IP67

Q1	Q1AA10150DXS00M	1500	3000	4500	4.79	4.90	14.7	1.61x10 <sup>-4</sup>	8000	6.5	RS1A05 RS1J05
	Q1AA13300DXS00M	3000	3000	4500	9.50	10.80	28.4	4.92x10 <sup>-4</sup>	8000	11.4	RS1A10

Protection degree Q1 SERIES: IP67

NOTE 1: all motors can be supplied in the version with **24 VDC holding brake**.

NOTE 2: the R Series Motors can be supplied, on demand, in the version with **absolute encoder**.

## OVERLOAD CURVES

This example shows the R2 100W motor's overload curve.

Note that a torque equal to 200% of the nominal torque can be kept for approx. 14 seconds.

A torque that is 400% of the nominal torque can be kept for approx. 3 seconds.

The overload curves of all the other motors have similar characteristics.

The possibility of using the motor in overload conditions for rather long time allows to choose, in different applications, smaller and compact motors, reducing mechanical volumes and to cut costs.

OVER LOAD CHARACTERISTICS  
Servo Motor: R2AA04010FXH1CM  
Servo Amplifier: RS1A01

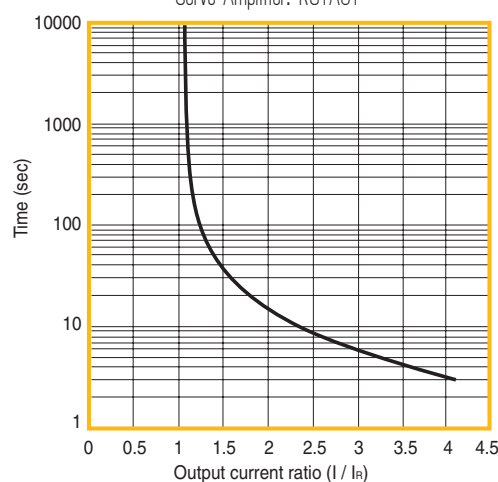

# TORQUE CURVES

The following diagrams show motor torques delivered according to speed variation (rpm). For each diagram two zones are indicated:

- **Continuous zone:** torque delivered by the motor continuously with a 100% duty cycle
- **Instantaneous zone:** torque delivered by the motor with a duty cycle below 100%. The maximum duty cycle that can be obtained in the Instantaneous zone depends on different factors, such as the system inertia. See the R Instruction Manual or contact RTA engineers for a correct dimensioning of the system. In a few motors, the Instantaneous Zone is furtherly divided into two parts, according as the power supply is of the single-phase or three-phase type.

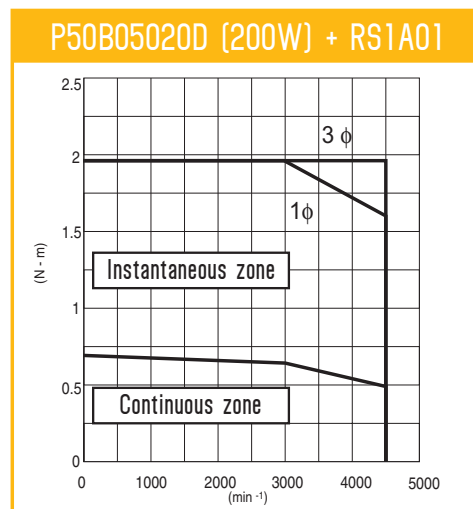
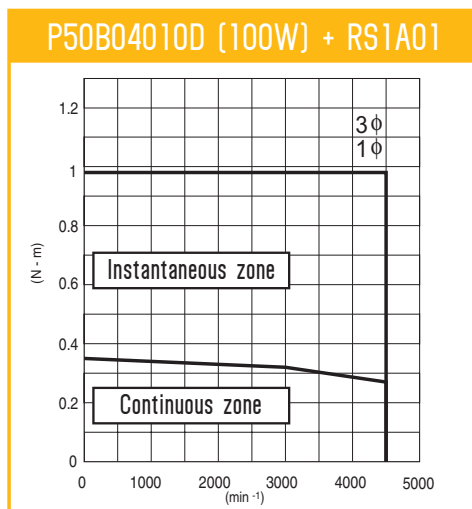
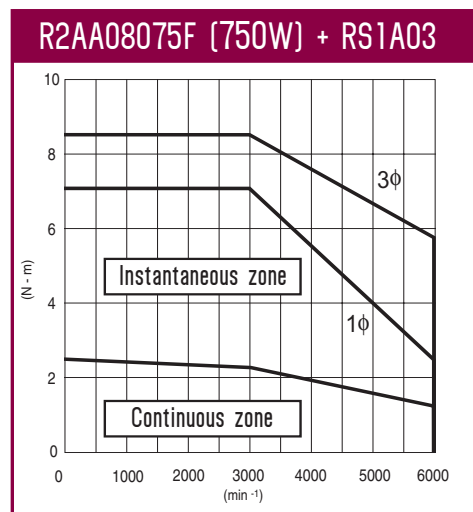
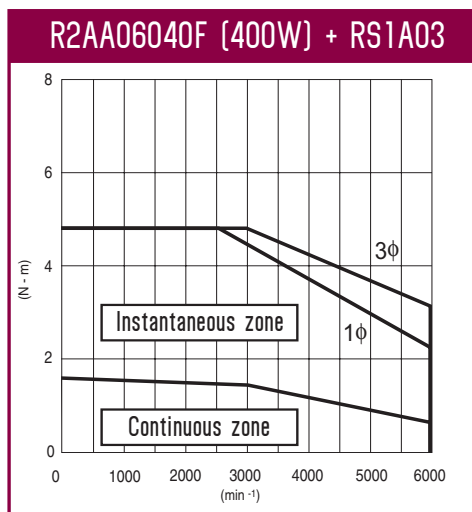
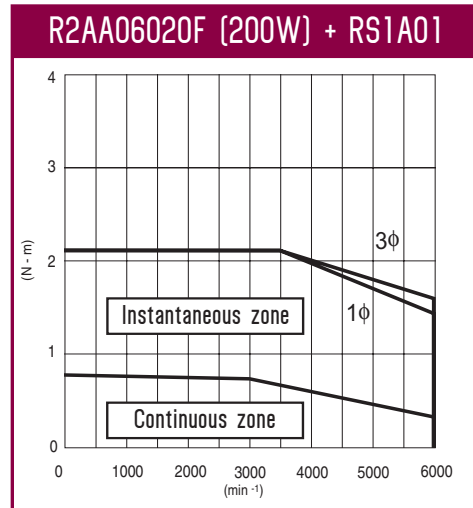
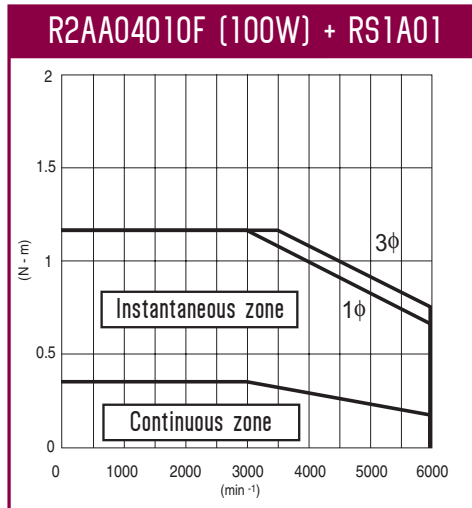

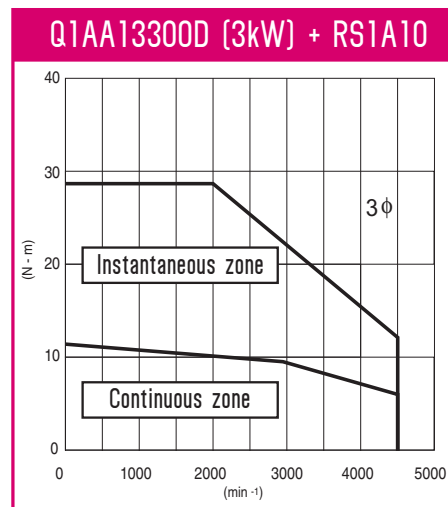
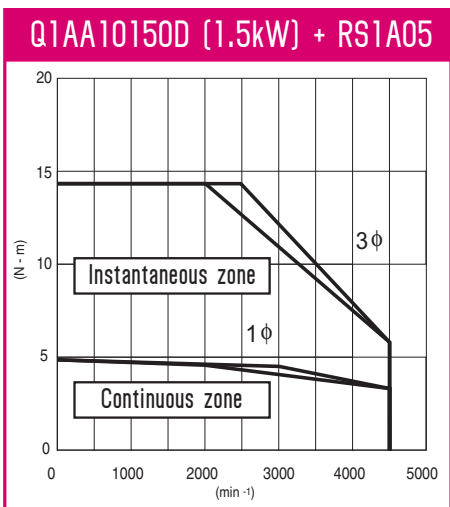
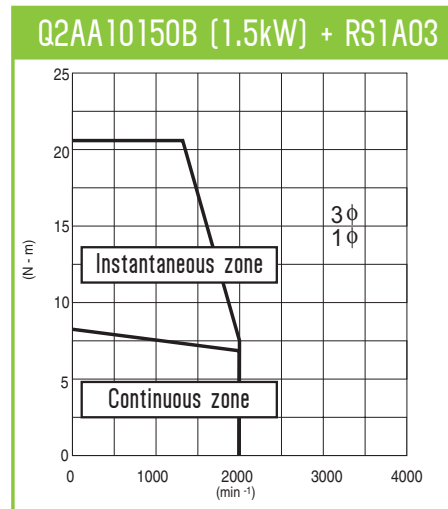
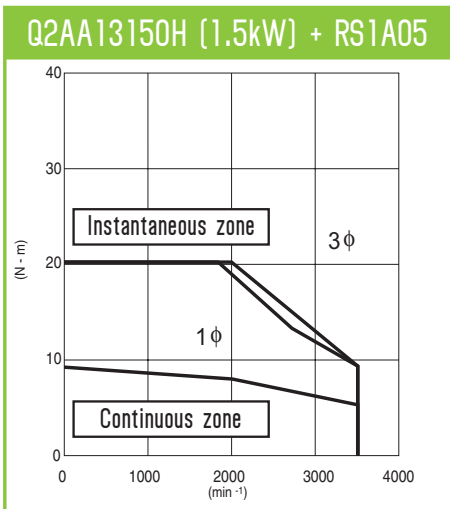
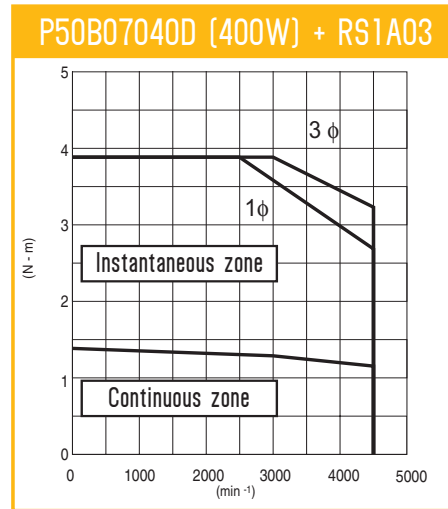
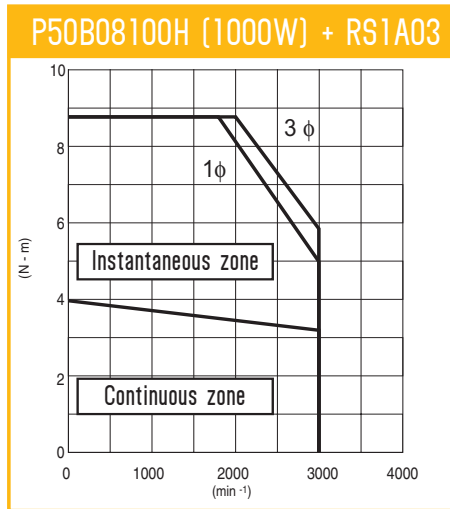

Indicated performances refer to motors controlled by related R amplifiers, standard and CANopen versions.

1 φ = torque curve with single-phase power supply

3 φ = torque curve with three-phase power supply





## SANYO DENKI P5 SERIES SERVOMOTORS

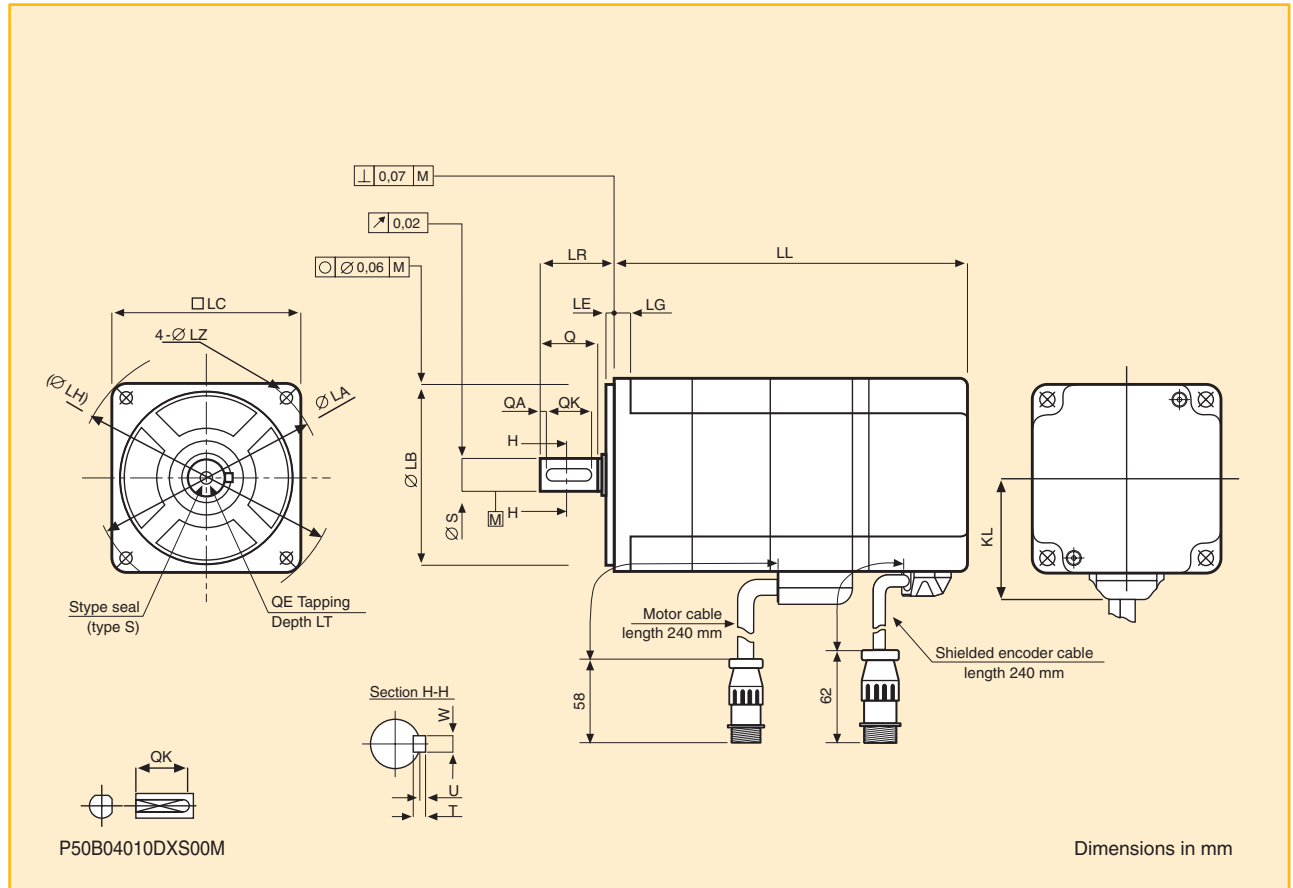

P5 SERIES	MODEL	without brake	with brake														Q	Q	Q	W	T	U	Q	L
		LL	LL	LG	KL	LA	LB	LE	LH	LC	LZ	LR	S	Q	A	K								
	P50B04010DXS00M	95	127	5	31	48	<sup>0</sup> <sub>34-0.025</sub>	2.0	57.0	42	3.5	24	<sup>0</sup> <sub>7-0.009</sub>	20	--	15	slotted, 2-faced, 6.5±0.2			--	--			
	P50B05020DXS00M	105	134	5	38	60	<sup>0</sup> <sub>50-0.025</sub>	2.5	71.5	54	4.5	30	<sup>0</sup> <sub>11-0.011</sub>	25	2	20	4	4	1.5	M4	10			
	P50B07040DXS00M	113	140	8	50	90	<sup>0</sup> <sub>70-0.030</sub>	3.0	102.5	76	5.5	30	<sup>0</sup> <sub>14-0.011</sub>	25	2	20	5	5	2	M5	12			
	P50B08100HXS00M	172	212	8	55	100	<sup>0</sup> <sub>80-0.030</sub>	3.0	115.0	86	6.6	35	<sup>0</sup> <sub>16-0.011</sub>	30	2	25	5	5	2	M5	12			



# SANYO DENKI

## Q2AA13150HXS00M SERVOMOTORS

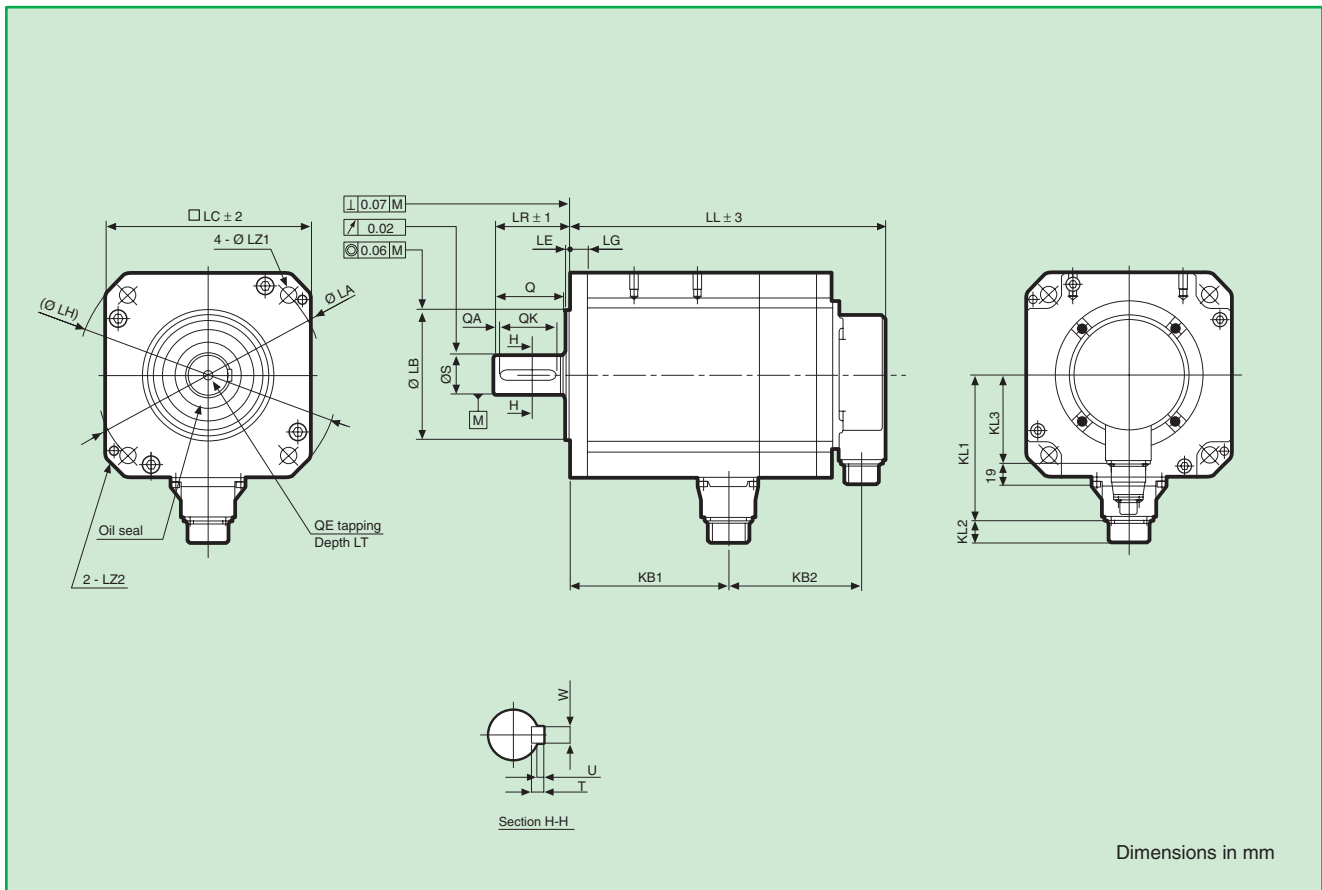

Q2 SERIES

MODEL

Q2AA13150HXS00M

without brake		with brake																							
LL	KB2	LL	KB2	KL1	KL2	KL3	LG	LA	LB	LE	LH	LC	LZ1	LZ2	LR	S	Q	QA	QK	W	T	U	KB1	QE	LT
169	67	205	103	98	21	80	12	145	<sup>0</sup> <sub>110-0.035</sub>	4	165	130	9	M6	55	<sup>0</sup> <sub>22-0.013</sub>	50	3	42	<sup>0</sup> <sub>6-0.030</sub>	6	2.5	81	M6	20



## SANYO DENKI Q2AA10150BXS48M SERVOMOTORS

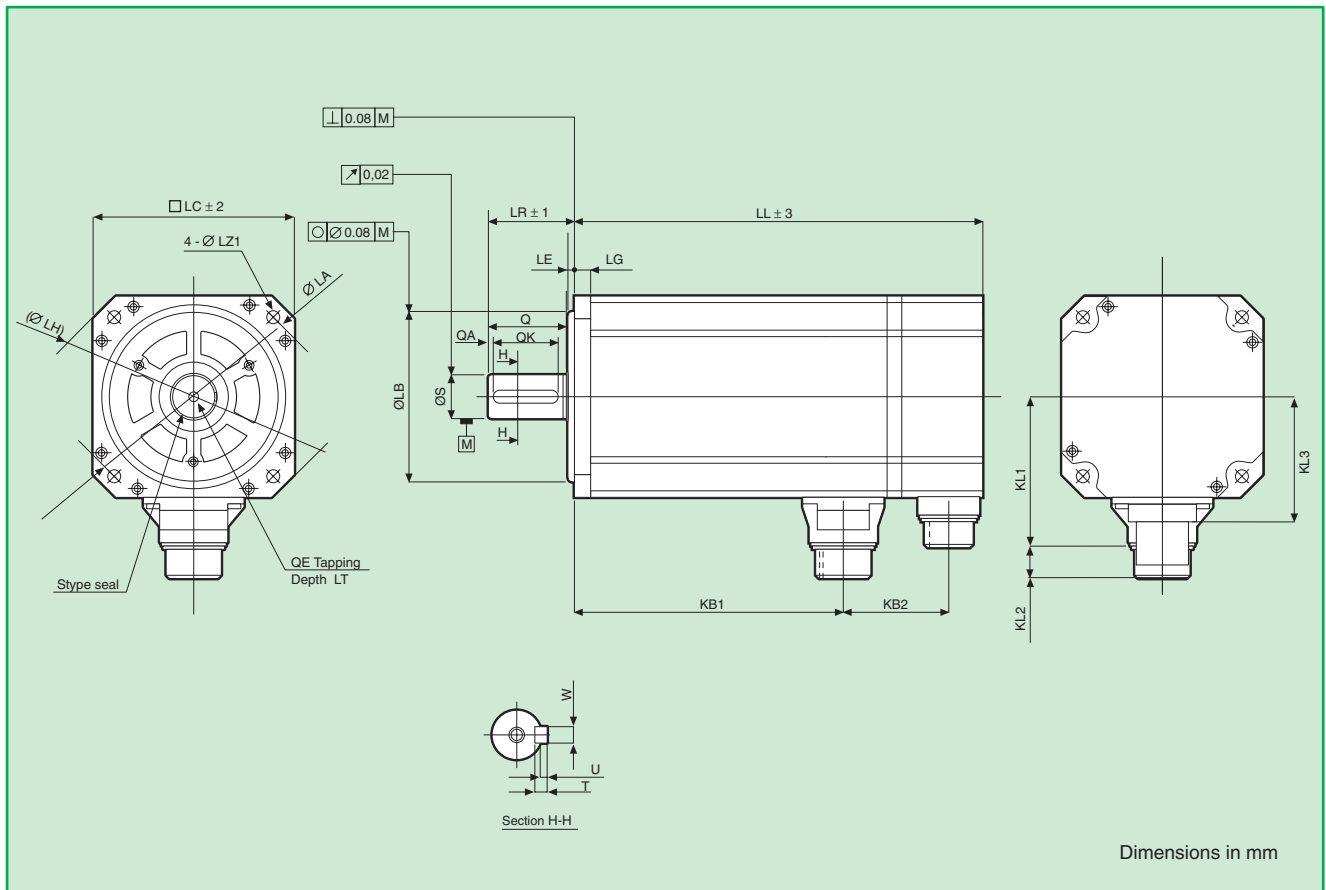

Q2 SERIES

MODEL

Q2AA10150BXS48M

without brake		with brake																						
LL	KB2	LL	KB2	KL1	KL2	KL3	LG	LA	LB	LE	LH	LC	LZ1	LR	S	Q	QA	QK	W	T	U	KB1	QE	LT
226	77	261	113	78	19	67	10	115	$\overset{0}{95-0.035}$	3	130	100	9	45	$\overset{0}{22-0.013}$	40	3	32	$\overset{0}{6-0.030}$	6	2.5	128	M6	20



# SANYO DENKI

## Q1AA10150DXS00M SERVOMOTORS

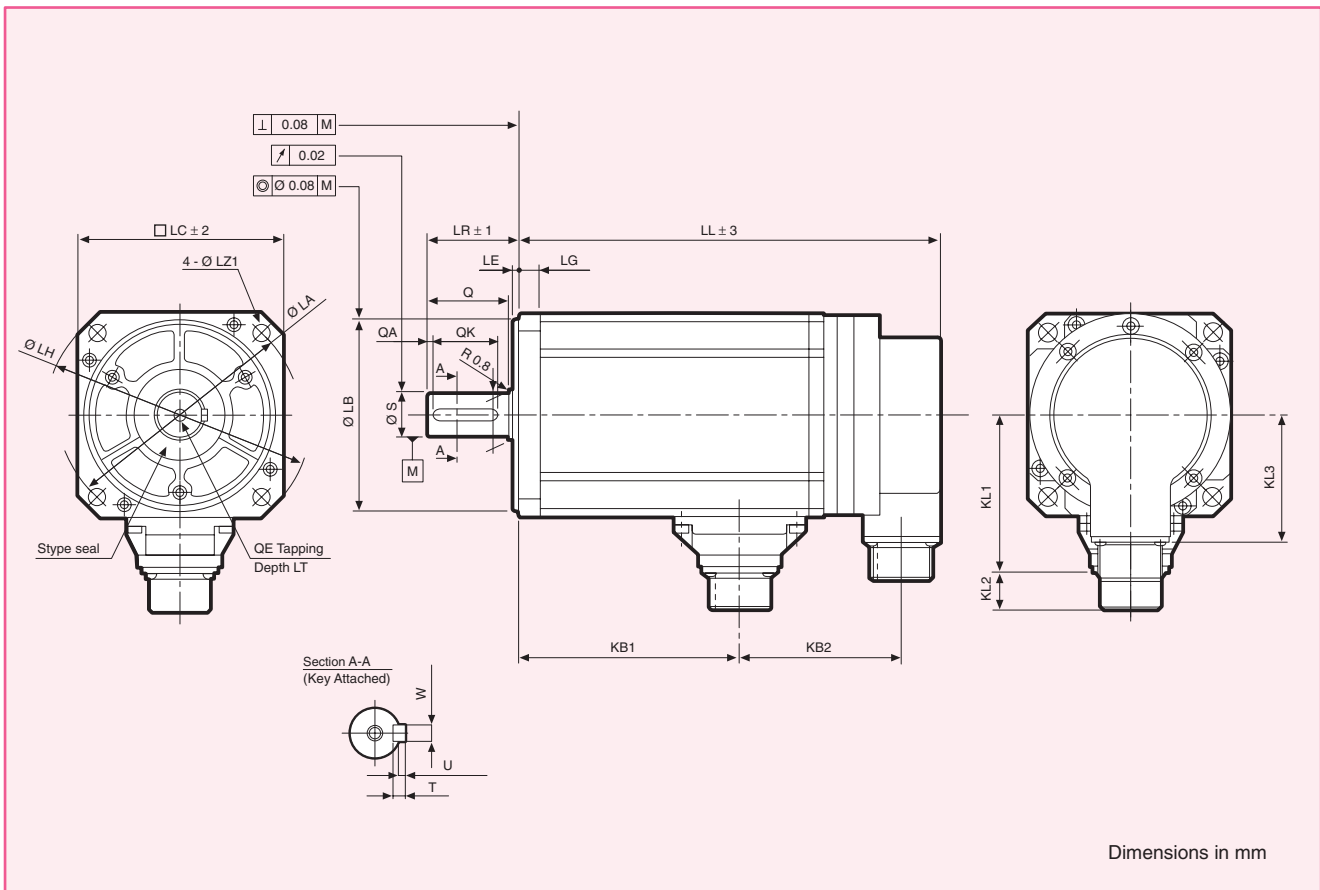

**Q1 SERIES**

**MODEL**

Q1AA10150DXS00M

without brake		with brake																						
LL	KB2	LL	KB2	KL1	KL2	KL3	LG	LA	LB	LE	LH	LC	LZ1	LR	S	Q	QA	QK	W	T	U	KB1	QE	LT
208	80	244	116	78	19	70	10	115	$0_{95-0.035}$	3	130	100	9	45	$0_{22-0.013}$	40	3	32	$0_{6-0.03}$	6	2.5	109	M6	20



## SANYO DENKI Q1AA13300DXS00M SERVOMOTORS

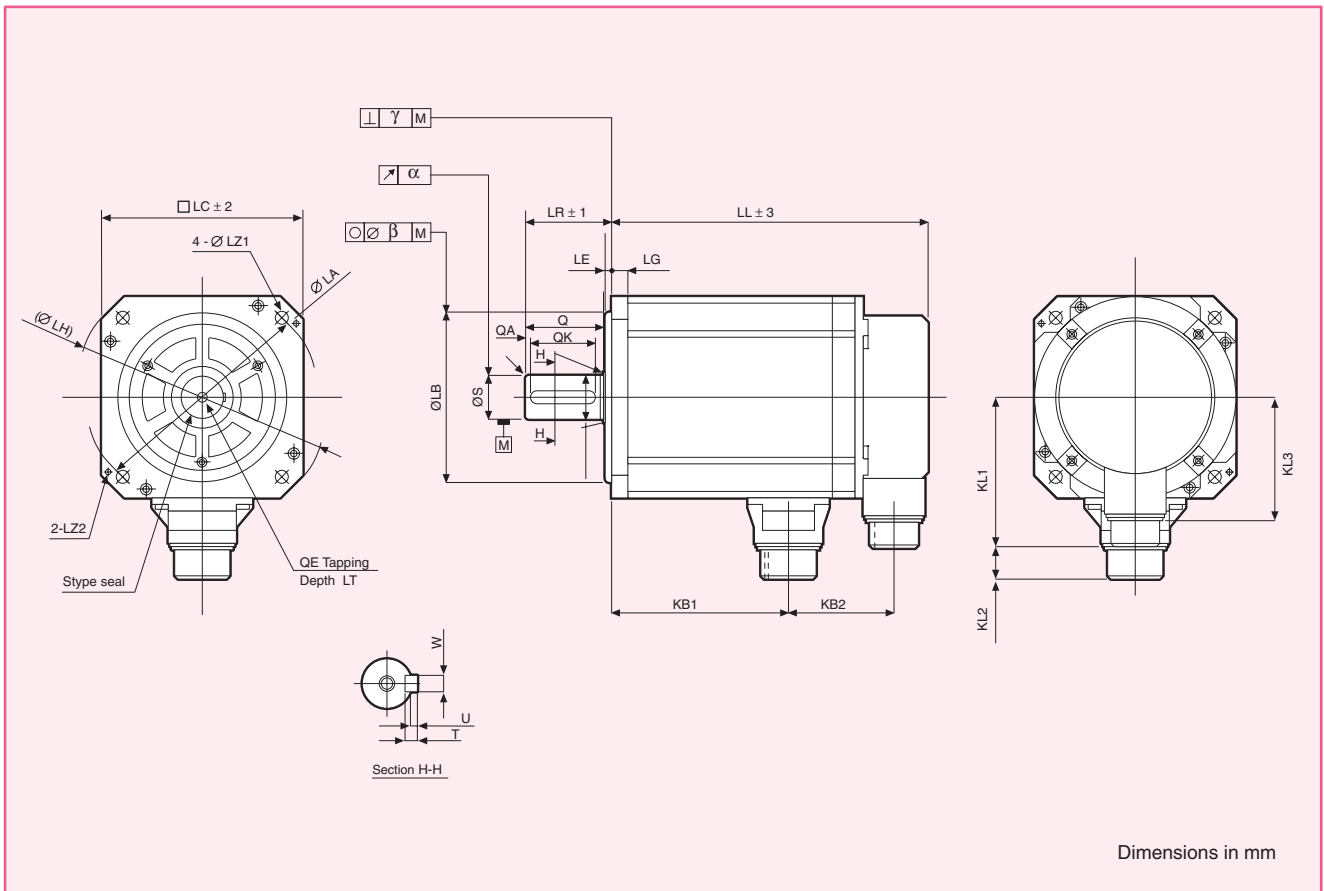

**Q1 SERIES**

**MODEL**

Q1AA13300DXS00M

without brake		with brake																							
LL	KB2	LL	KB2	KL1	KL2	KL3	LG	LA	LB	LE	LH	LC	LZ1	LZ2	LR	S	Q	QA	QK	W	T	U	KB1	QE	LT
205	67	254	117	98	21	78	12	145	0 110-0.035	4	165	130	9	M6	55	0 28-0.013	50	3	42	0 8-0.036	7	3	117	M8	25





AC SERVOAMPLIFIERS  
RS1A SERIES  
STANDARD VERSION  
OUTLINE DRAWINGS

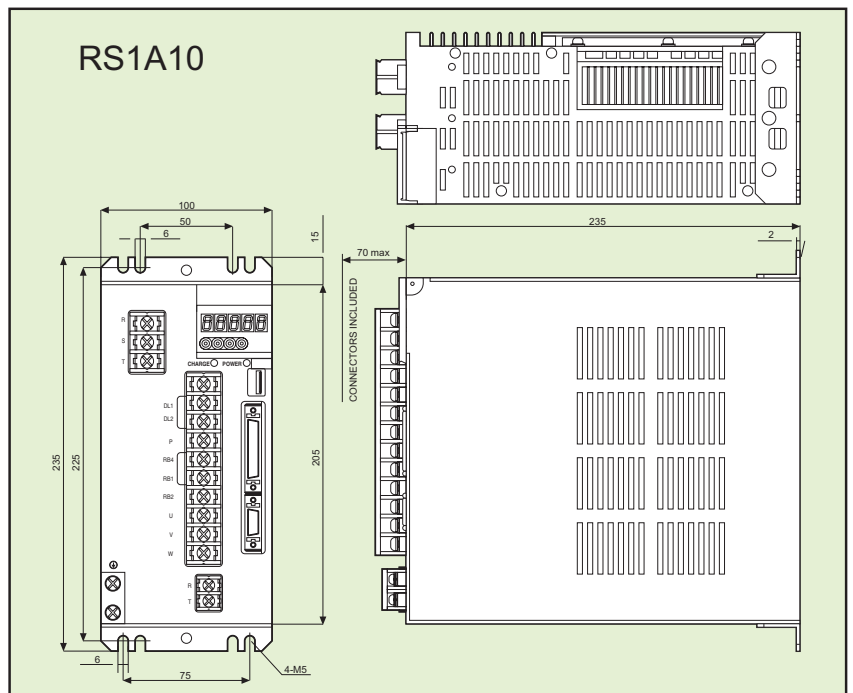
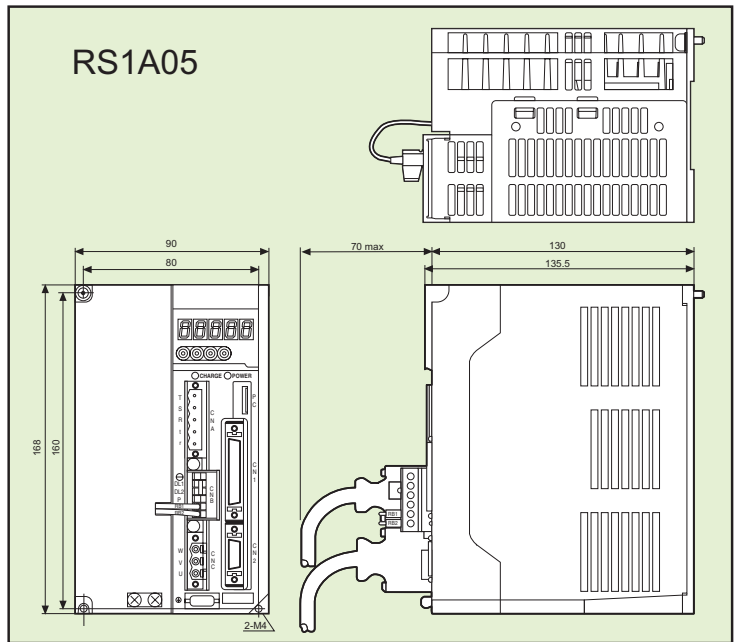
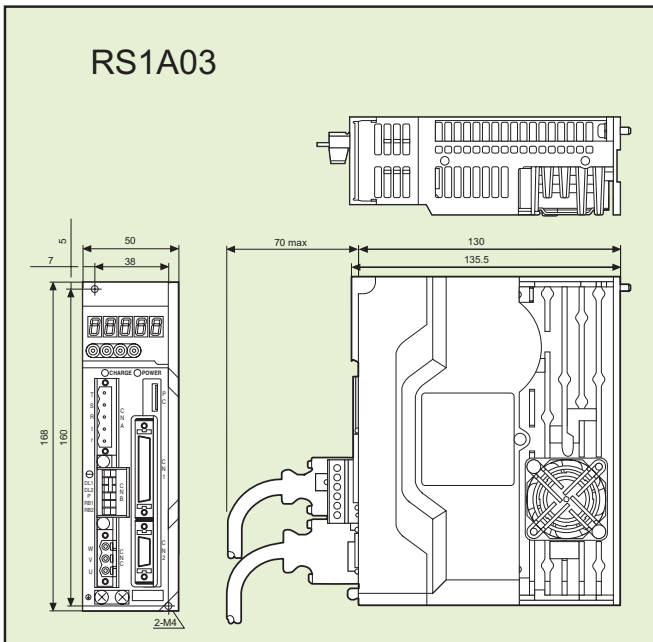
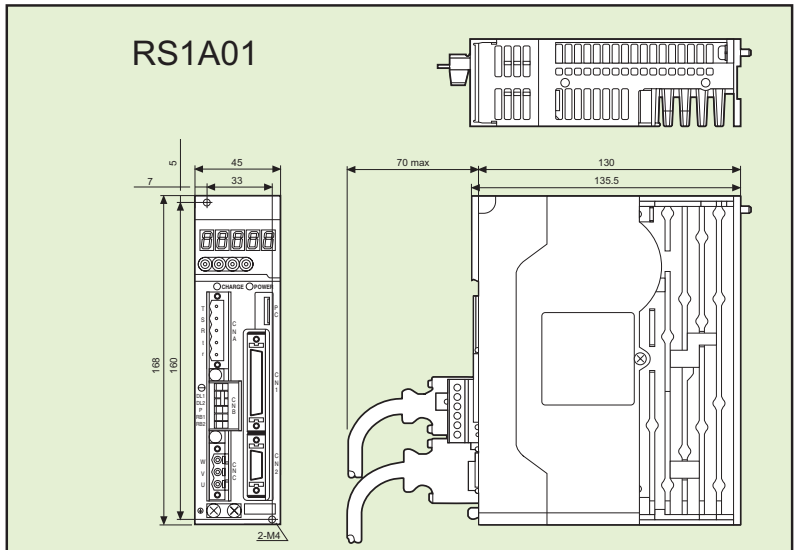

Dimensions mm



## AC SERVOAMPLIFIERS RS1J SERIES CANopen VERSION OUTLINE DRAWINGS

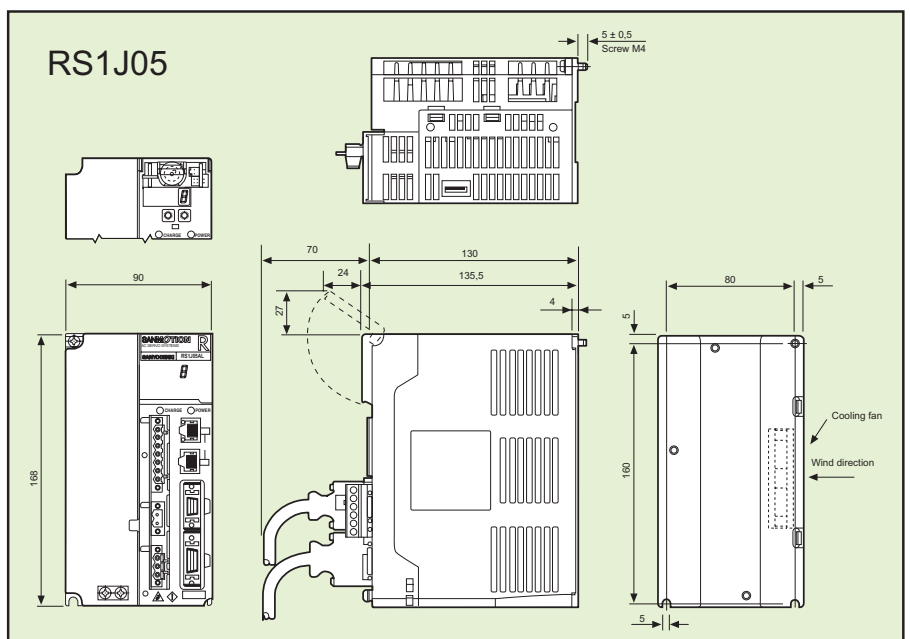
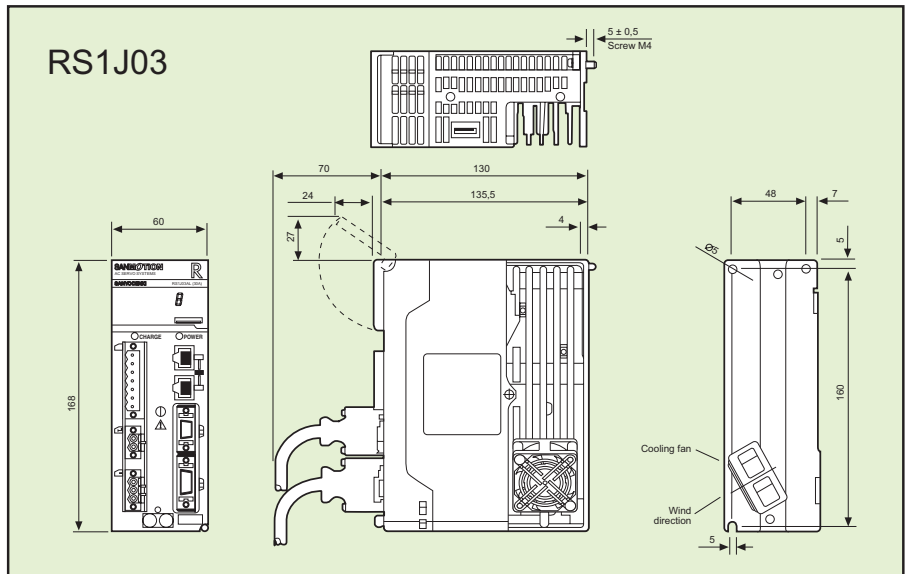
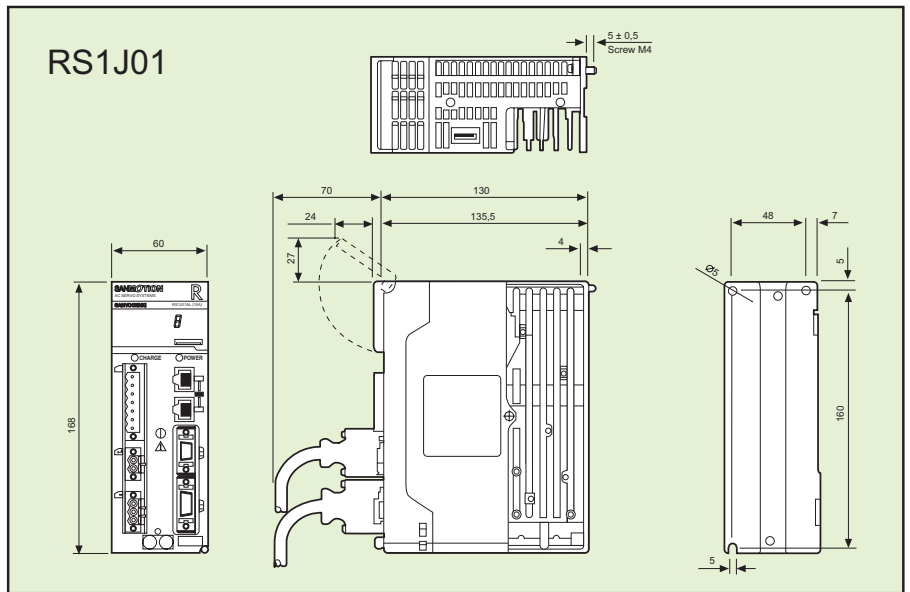

Dimensions mm

# ACCESSORIES

## SERIAL CONNECTION KIT: STARTER KIT RSK

The kit includes:

- Serial connection cable [length 3 m]
- R.T.A. - R Series CD-Rom: includes R - Setup Software and Manuals

## AMPLIFIER-MOTOR CONNECTION CABLES

All motors supplied are already equipped with high quality connectors.

To ease installation, connection cables of different length are available, for any motor-amplifiers coupling. The available codes are detailed below:

MOTORS	CABLES	LENGTHS				
		1 meter	2 meters	3,3 meters	5 meters	10 meters
R2	POWER SUPPLY CABLE	CVABPY1M	CVABPY2M	CVABPY3M3	CVABPY5M	CVABPY10M
	MOTOR CABLE	CVMBPY1M	CVMBPY2M	CVMBPY3M3	CVMBPY5M	CVMBPY10M
	ENCODER CABLE	CVEBR01M	CVEBR02M	CVEBR03M3	CVEBR05M	CVEBR10M
	BRAKE CABLE	CVFRPM01M	CVFRPM02M	CVFRPM03M5	CVFRPM05M	CVFRPM10M
P5	POWER SUPPLY CABLE	CVABPY1M	CVABPY2M	CVABPY3M3	CVABPY5M	CVABPY10M
	MOTOR CABLE	CVMBPY1M	CVMBPY2M	CVMBPY3M3	CVMBPY5M	CVMBPY10M
	ENCODER CABLE	CVEB1M	CVEB2M	CVEB3M3	CVEB5M	CVEB10M
	MOTOR CABLE WITH BRAKE	CVMBFPY1M	CVMBFPY2M	CVMBFPY3M3	CVMBFPY5M	CVMBFPY10M
Q2	MOTOR CABLE (Q2AA10150BXS48M)	CVMBPYP21M	CVMBPYP22M	CVMBPYP23M3	CVMBPYP25M	CVMBPYP210M
	MOTOR CABLE (Q2AA13150HXS00M)	CVMBPYP61M	CVMBPYP62M	CVMBPYP63M3	CVMBPYP65M	CVMBPYP610M
	ENCODER CABLE	CVEBP61M	CVEBP62M	CVEBP63M3	CVEBP65M	CVEBP610M
	BRAKE CABLE	CVFPM01M	CVFPM02M	CVFPM03M5	CVFPM05M	CVFPM10M
Q1	MOTOR CABLE (Q1AA10150DXS00M)	CVMBPYP21M	CVMBPYP22M	CVMBPYP23M3	CVMBPYP25M	CVMBPYP210M
	MOTOR CABLE (Q1AA13300DXS00M)	CVMBQA10Q301M	CVMBQA10Q302M	-	CVMBQA10Q305M	CVMBQA10Q310M
	ENCODER CABLE	CVEBP61M	CVEBP62M	CVEBP63M3	CVEBP65M	CVEBP610M
	BRAKE CABLE	CVFPM01M	CVFPM02M	CVFPM03M5	CVFPM05M	CVFPM10M

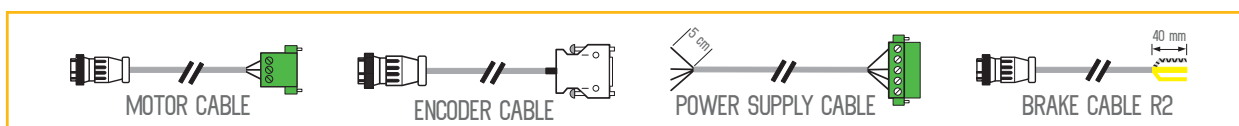

Flex chain cables available under request.

## EXTERNAL REGENERATIVE RESISTOR

Under special conditions of use, such as, for example, sudden decelerations with high inertial load, it may be necessary to dissipate outside the reverse energy generated by the motor.

This need is signaled by the amplifier through a specific alarm. Any excessive energy is dissipated outside through a regenerative resistor. The following models are available on demand:

AMPLIFIER	RESISTOR MODEL	VALUE ( $\Omega$ )	POWER (W)
 RS1A01/RS1J01 RS1A03/RS1J03 RS1A05/RS1J05 RS1A10	RB 10006 - 220W/100 OHM	100	220
	RB 05005 - 220W/ 50 OHM	50	220
	RB 02030 - 500W/ 20 OHM	20	500
	RB 01030 - 500W/ 10 OHM	10	500



**HEADQUARTERS**

**R.T.A. s.r.l.** - Via E. Mattei  
Fraz. Divisa - 27020 MARCIGNAGO (PV)  
Tel. +39.0382.929.855 - Fax +39.0382.929.150  
www.rta.it - e-mail: info@rta.it

**FILIALE NORD-EST**

Via D. Alighieri, 4/A - 30034 MIRA (VE)  
Tel. +39.041.56.00.332 - Fax +39.041.56.00.165  
e-mail: rtane@rta.it

**FILIALE CENTRO-SUD**

Via D. Alighieri, 41 - 60025 LORETO (AN)  
Tel. +39.071.75.00.433 - Fax +39.071.97.77.64  
e-mail: rtacs@rta.it

**R.T.A. Deutschland GmbH**

Bublitzer Straße, 34  
40599 DÜSSELDORF (Germany)  
Tel. +49.211.749.668.60  
Fax +49.211.749.668.66  
www.rta-deutschland.de  
e-mail: info@rta-deutschland.de

**R.T.A. IBERICA - Motion Control Systems S.L.**

C/ Generalitat 22, 1º 3º  
08850 GAVA - BARCELONA (Spain)  
Tel. +34. 936. 388. 805  
Fax +34. 936. 334. 595  
www.rta-iberica.es  
e-mail: info@rta-iberica.es

