

T IS THE EARTH TERMINAL.

Dimensions in mm.

FEATURES CARATTERISTICHE		
MODEL MODELLO		103 - H7126 - 6640 (103 - H7126 - 6610)
BASIC STEP ANGLE		1.8° ± 0.09°
BIPOLAR CURRENT	(Amp)	5.6
UNIPOLAR CURRENT	(Amp)	
RESISTANCE	(Ohm)	0.3
INDUCTANCE	(mH)	0.85
BIPOLAR HOLDING TORQUE	(Ncm)	165
UNIPOLAR HOLDING TORQUE	(Ncm)	
ROTOR INERTIA	(Kgm ² x 10 ⁻⁷)	360
THEORETICAL ACCELERATION	(rad x sec. ⁻²)	45800
BACK E.M.F.	(V/Krpm)	23
MASS	(Kg)	1
PROTECTION DEGREE		IP43
LEADS CODE		V

Codes between brackets refer to double shaft models.
Le sigle fra parentesi si riferiscono ai modelli bialbero.

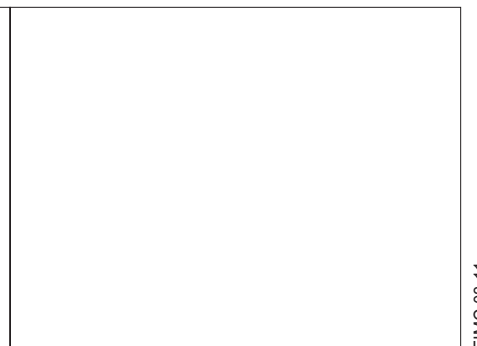
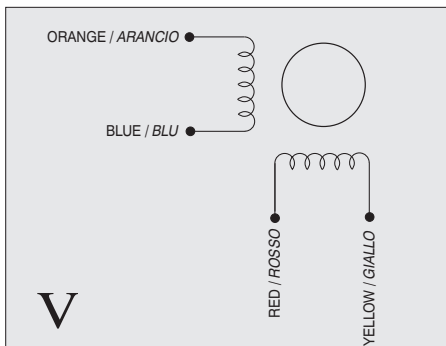
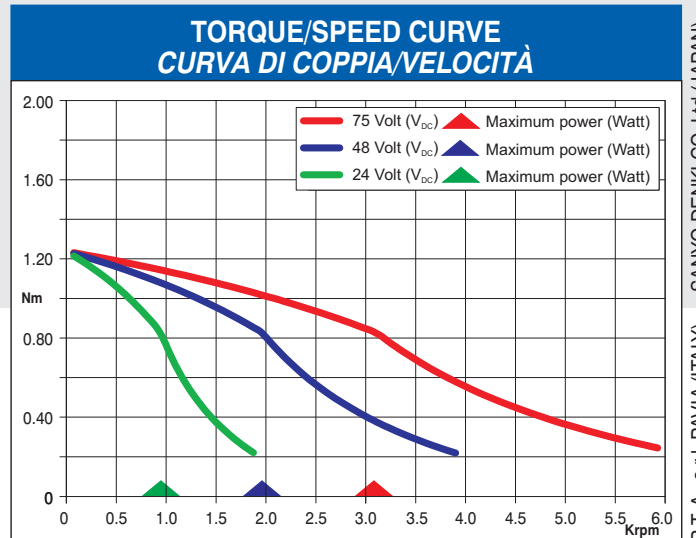

Suggested R.T.A. driver: NDC Series, HGD Series, PLUS Series.



R.T.A. s.r.l.
Via E. Mattei - Fraz. Divisa
27020 MARCIGNAGO (PV) ITALY
Tel. +39.0382.929.855 - Fax +39.0382.929.150
www.rta.it

R.T.A. Deutschland GmbH
Bublitzer Straße 34
40599 DÜSSELDORF (Germany)
Tel. +49.211.749.668.60 - Fax +49.211.749.668.66
www.rta-deutschland.de

R.T.A. IBERICA-Motion Control Systems S.L.
C/Generalitat 22, 1° 3°
08850 GAVA - BARCELONA (Spain)
Tel. +34.936.388.805 - Fax +34.936.334.595
www.rta-iberica.es